



Engine	Cummins QSB5.9
Rated Power	154 kW (207 hp / 210 ps) @ 2,200 rpm
Milling Width	1,000 mm
Max. Milling Depth	180 mm
Number of Tools	92
Operating Mass	14,500 kg

5100-2 Cold Planer

5100-2 SPECIFICATIONS >>>

ENGINE

Emission Regulation	Tier 3 / Stage III
Make	Cummins
Model	QSB5.9-C210
Rated Power	154 kW (207 hp / 210 ps) @ 2,200
Peak Torque	820 N · m
Number of Cylinders	6
Aspiration	Turbo, air-to-air, aftercooled
Cooling Type	Water

ELECTRICAL SYSTEM

System Voltage	24 V
----------------	------

SERVICE CAPACITIES

Fuel Tank	370 L
Hydraulic Fluid Tank	100 L
Water Tank	920 L

DRIVING PROPERTIES

Driving	Four-wheel drive
Driving Modle	Full Hydraulic
Travel Speed	0~8 km/h
Milling Speed	0~30 m/min
Theoretical Gradability, Milling Gear / Travel Gear	86% / 12%

TYRES

Type of Tyres	Solid rubber
Tyre Diameter	660 mm
Tyre Width	255 mm

WORKING DIMENSIONS

A	B	C	D	E	F
1,350	1,690	2,000	3,760	2,830	10,800
G	H	I	J	K	L
8,200	2,850	3,560	1,150	2,500	4,950
M	N	α	β		
1,645	2,680	20°	25°		

Unit: mm

MILLING DRUM

Milling Width	1,000 mm
Milling Depth	0~180 mm
Tool Spacing	15 mm
Number of Tools	92
Drum Diameter with Tools	750 mm
Speed of Milling Drum	150 rpm
Max. Inclined Angle of Milling Drum	≤ 5°

OPERATING MASS

Operating Mass	14,500 kg
Load on Front Wheel	6,400 kg
Load on Rear Wheel	6,600 kg

CONVEYOR SYSTEM

Conveyor Height	3,760 mm
Belt Width	400 mm
Theoretical Conveyor Capacity	82 m ³ /h

OPTIONS

Conveyor for 4,500 mm

SHIPPING DIMENSIONS

Shipping Dimension (Conveyor Fold) (L x W x H) 8,200 × 2,460 × 2,850 mm

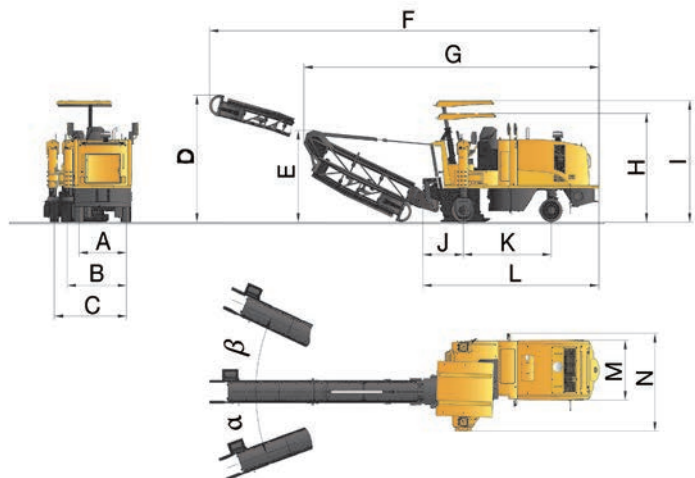

Guangxi Liugong Machinery Co., Ltd.

No. 1 Liutai Road, Liuzhou, Guangxi 545007, PR China
T: +86 772 3886124 E: overseas@liugong.com
www.liugong.com

Specifications and designs are subject to change without notice. Machines shown may include optional equipment. Liugong standard and optional equipment may vary from region to region. Please consult your Liugong dealer for information specific to your area. Engine power kW is converted to horsepower (1 kW=1.3596 ps and 1 kW=1.3410 hp) in this file.

04/2020 Designed by LiuGong
Replace the previous versions of 09/2019